

"Preliminary DWG"

INSTALLATION IN VERTICAL PIPELINE
VALVE STEM HORIZONTAL

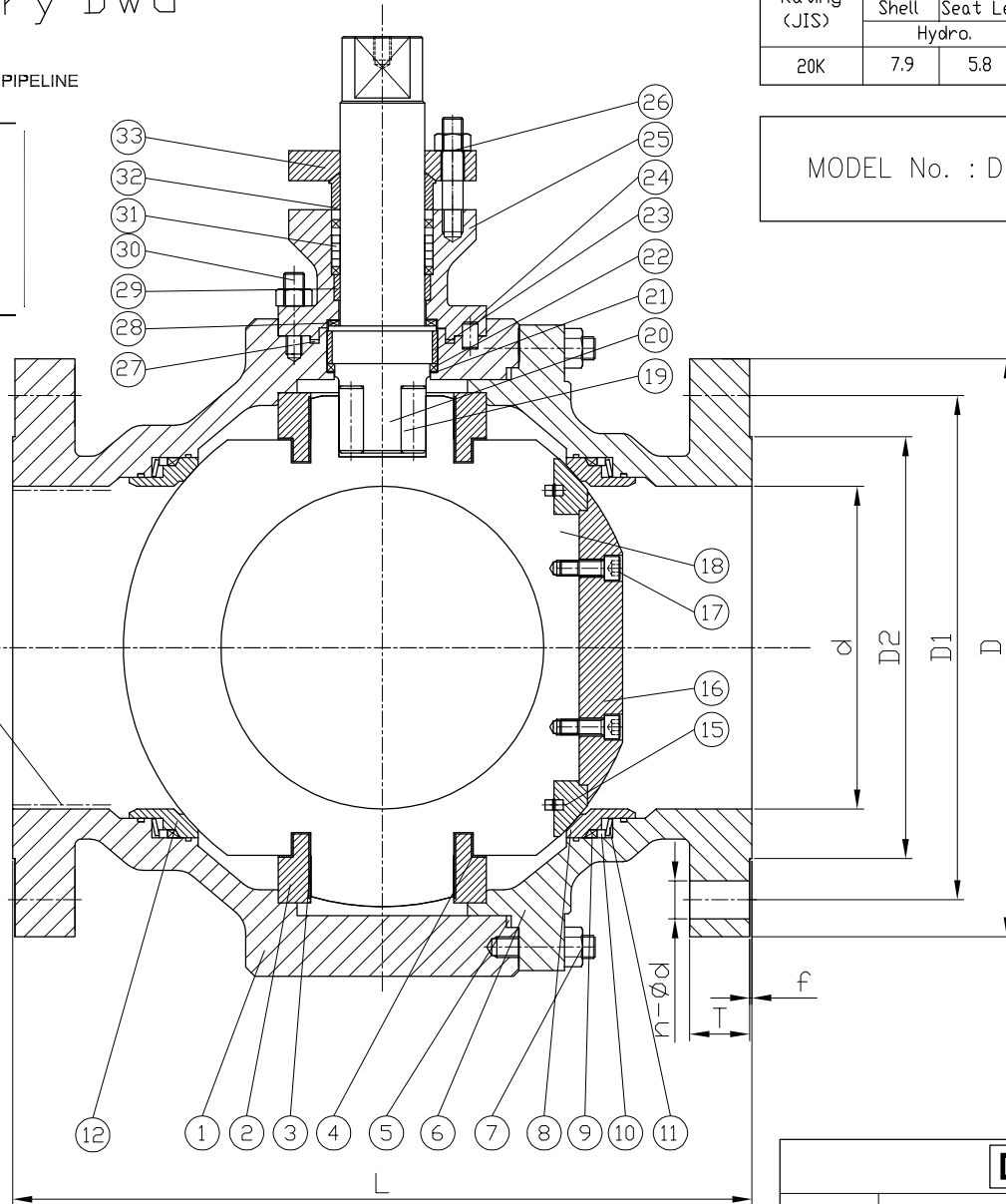
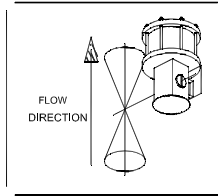

Pressure Rating (JIS)	Test Pressure(Mpa)		Applicable Temp. (°C)	
	Shell	Seat Leakage		
	Hydro.	Air		
20K	7.9	5.8	0.6	-25~+180

MODEL No. : D100-PS83

DESIGN STANDARD

1. Design and Manufacture : ASME B16.34
2. Face to Face Dimension : JIS B2002 (or Customer Requested)
3. Test Standard : API 598
4. End Connection : JIS B2220
5. Applicable Temp(°C) -25~+180'
6. Seat Leakage : Class V by ANSI B16.104(FCI 70-2)

No.	Description	Material	Remark
33	Gland Flange	ASTM A276 304	
32	Gland Ring	ASTM A276 304	
31	Gland Packing	Graphite Mold	
30	Bonnet Bolt	ASTM A193 B8	
29	Lantern Ring	Oilless Bearing	
28	Thrust Washer-3	Hard PEEK	
27	Bonnet Gasket	SPW304 + Graphite	
26	Gland Bolt	ASTM A193 B8	
25	Bonnet	ASTM A276 304	
24	Pin	ASTM A276 304	
23	Stem Bush	Oilless Bearing	
22	Thrust Washer-2	Hard PEEK	
21	Thrust Washer-1	ASTM A276 304	
20	Stem	ASTM A564 630+CVD	
19	Stem Pin	ASTM A276 304	
18	Ball	ASTM A276 304+TCC	HV 940
17	Press Cover Bolt	ASTM A193 8M/CVD	HV 1600
16	Press Cover	ASTM A276 304+TCC	HV 940
15	Ball Insert Ring	STC/CVD	HV 1600
12	Solid Seat	STC/CVD	HV 1600
11	Spring	X-750	
10	Seat Insert	ASTM A276 304	
9	Seat Packing	Graphite	
8	Seat	ASTM A276 304+TCC	HV 940
7	Body Bolt	ASTM A193 B7	
6	Cap	ASTM A105	
5	Body Gasket	SPW304 + Graphite	
4	Ball Guide Bush 2	Hard Peek	
3	Ball Guide Bush 1	Dry Bush	
2	Trunnion Pad	ASTM A182 F304	
1	Body	ASTM A105 / TCC	Outlet

DN200	20K	518	195	350	305	275	28	2	12-ø25
NPS	Class	L	d	D	D1	D2	T	f	n-ød

DHCv DaehanCVD Co.,Ltd www.cvdvalve.com				Scale				Projection	
				Title				Trunnion Ball Valve DN200 JIS20K, RF	
DHCv	Signature	GS LEE	DH KIM	-	JS PARK	Date	June. 27.2022	June. 27.2022	June. 27.2022
	Date	June. 27.2022	June. 27.2022		June. 27.2022				
REF. Dwg. No. : Manufacture No. : Stock No. : Dwg. No. :				DHCv Dwg. No. : TA83-P02206-000					